

Wakefield Thermal Solutions Inc

Jeff Divers

**SOLID STATE LIGHTING SEMINAR
EVEREST SALES AND SOLUTIONS
GUADALAJARA**

28 August 2009

Background

- **Wakefield Thermal Solutions Inc** was established early 1950's Merged with **National Northeast** 2001 to become an integrated product supplier.



- Broad range of thermal management solutions and services.

- Markets Served

- LED / Lighting
- Solar & Wind Power
- Industrial Controls
- Power Supplies
- Medical & Instrumentation
- Transportation
- Power Conversion
- Telecommunications
- Military / Aerospace
- Consumer Goods / Products

- Marine
- Distribution
- Recreational
- Face Plates
- Hardware / Machinery
- Architectural
- Building & Construction
- HVAC



Subsidiaries

Simon Industries: Cary, NC

Heat Frames

Wedge Locks

Machined Housings

Highly Precision Components

www.simonindustries.com



Engineered Sintering and Plastics: Watertown, CT

Powdered Metal Applications

Gears

Over Molded Components

Injection Molded Components

www.engsint.com



Engineering-Capabilities

- Thermal Analysis

Spread sheet programs Natural & Forced Convection

Solid Works Flow Simulation

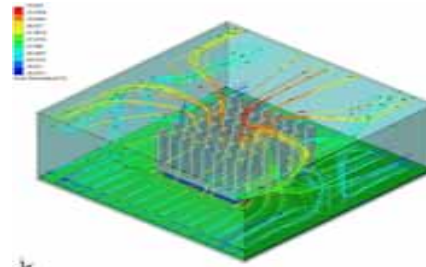

- Prototypes

- CNC Programming

- Auto Cad / Solid works / CAD CAM / Smart CAM

- Tooling Design & Manufacturing

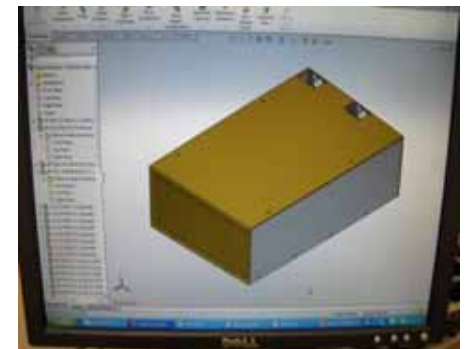

Quality

- ISO 9001:2000
Certificate of Registration Perry Johnson Registrars Inc
- Complete Inspection CMM
- Roving Quality Inspectors
- FAI's, PPAP
- Vendor Audits
- New Product Introduction



Why Use a Heat Sink?

A **heat sink** extends the life of the device that it is cooling..Acting like

a sponge to absorb the heat away from the device.

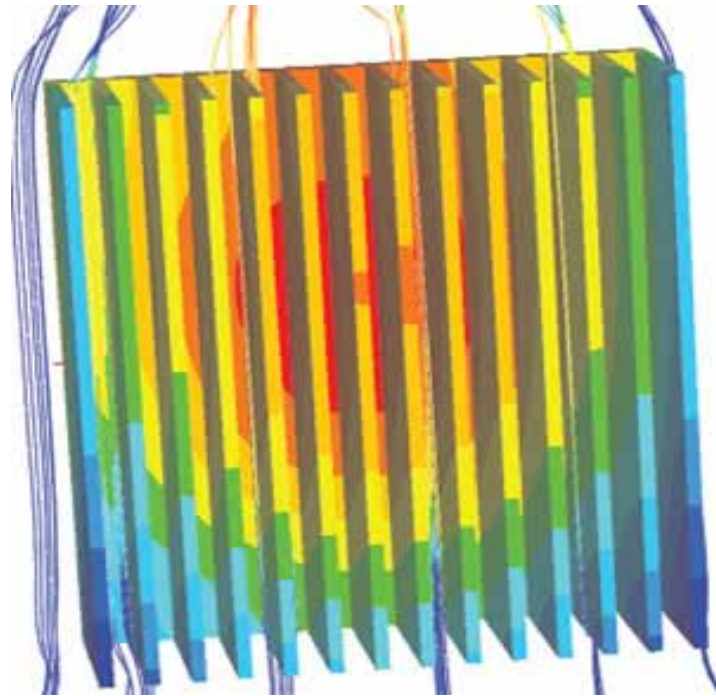

To keep it below max. operating temperature

Thermal Resistance

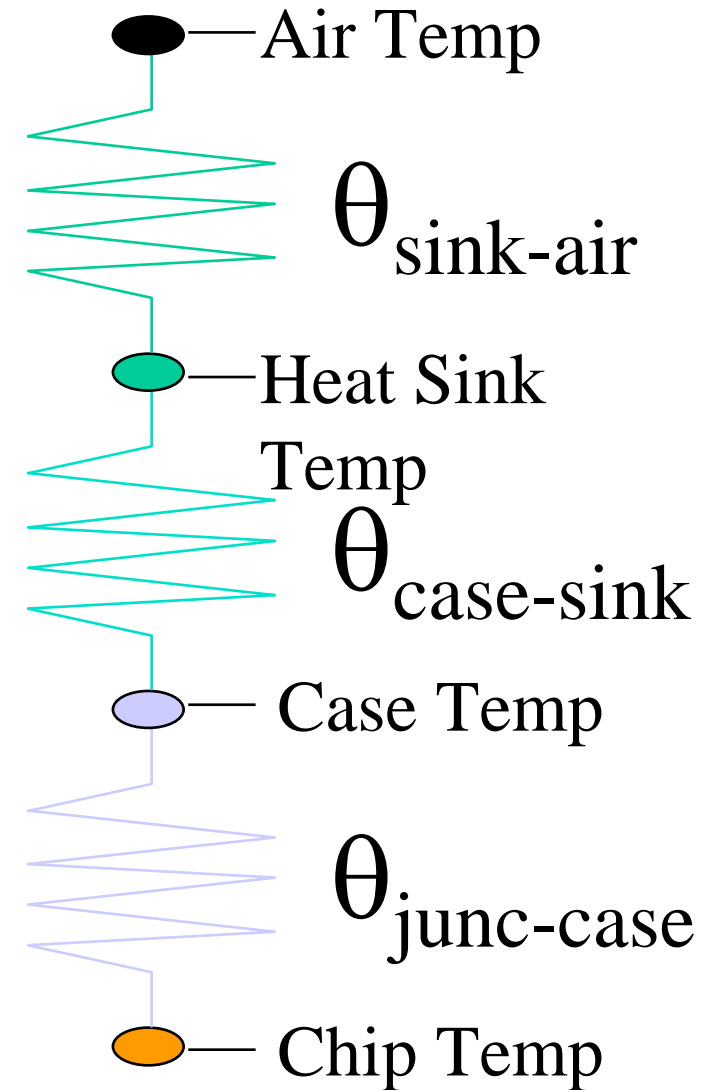
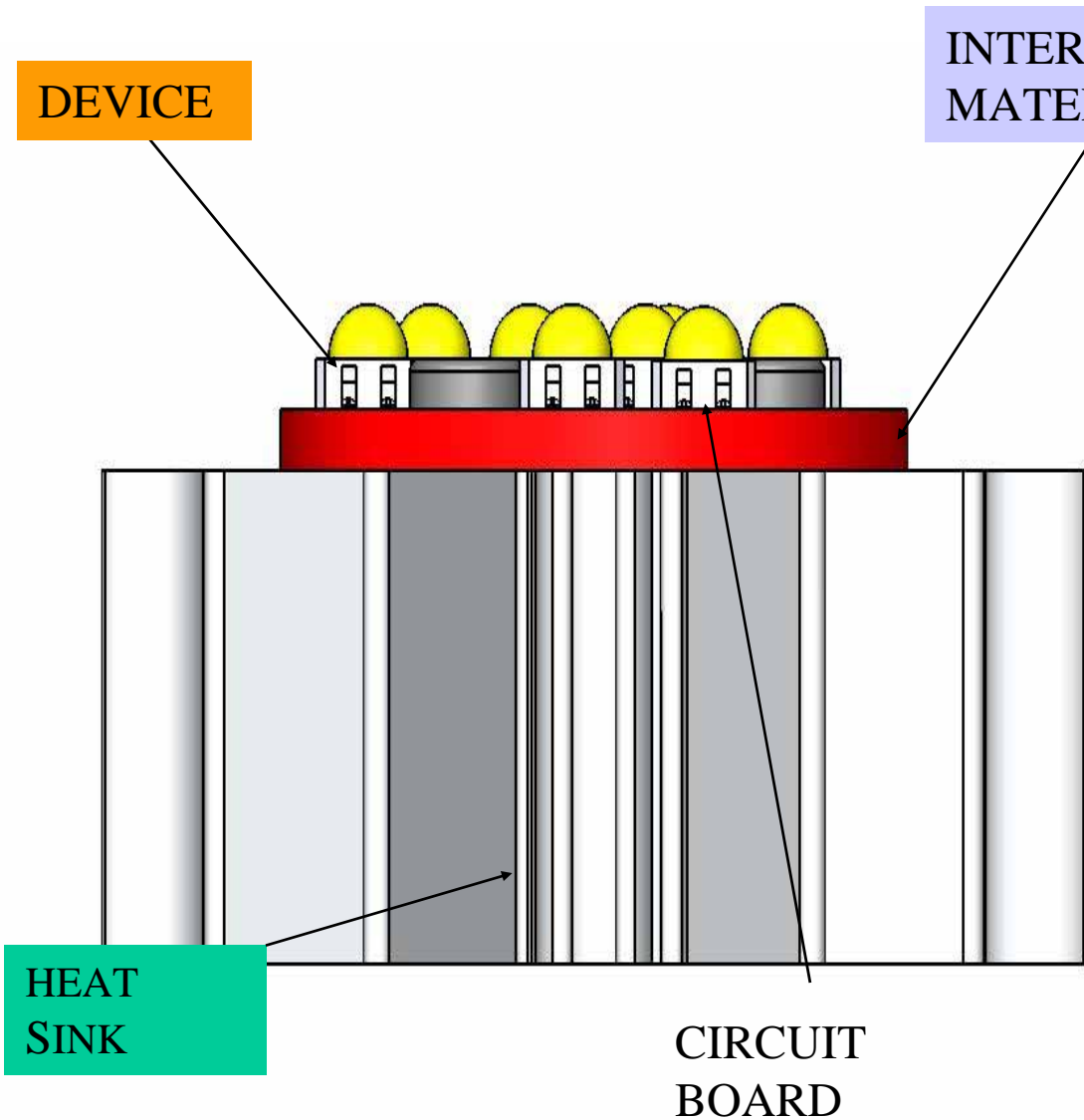

Sanity Check

Max operating temp. of device. 125C

Max ambient air temp. 40C

Junction to case thermal resistance value

(this is found on mfg data sheet) 5C/W

Case to sink thermal resistance (interface material) 1.0C/W

Equation:

$$(125\text{C}-40\text{C})/\text{Watts} - (\text{JC} + \text{CS}) = \text{Target C/W}$$

$$125\text{C}-40\text{C} = 85\text{C} / 6 \text{ watts} = 14.16\text{C/W} - 6\text{C/W}$$

$$= 8.16\text{C/W} \text{ Value Required for heat sink cooling}$$

Interface Materials - Why?

- Interface Materials fill in the voids between the heat sink and the device
- The voids have very low conductivity (air)
- Surface **Flatness** and Surface **Finish** cause the voids

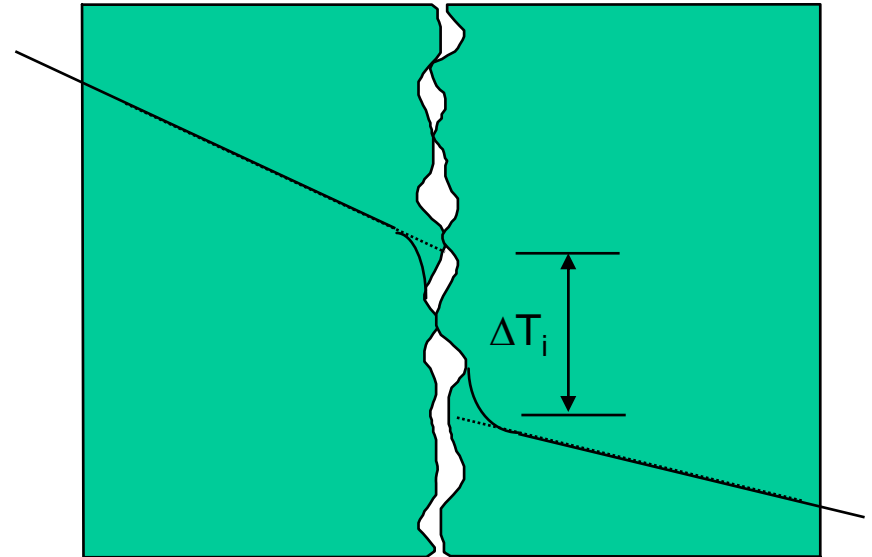

Exaggerated



Thermal Compound

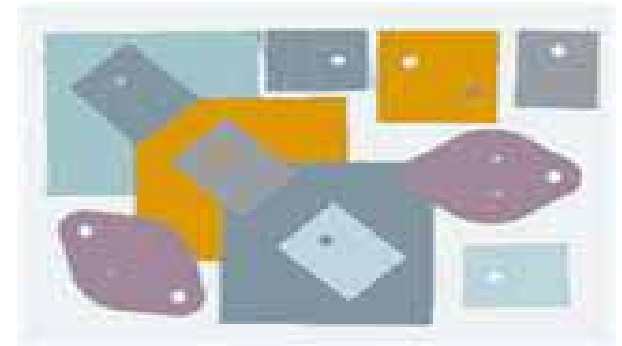

Thermal Pads

Heat Sink Technical Terms

- **Thermal Resistance:** ($^{\circ}\text{C}/\text{W}$) Temperature rise, in degrees Celsius, per Watt of power dissipated.
- **Ambient:** The environment that carries away the heat.
(Surrounding air temperature)
- **Interface Material:** Material (thermal compounds, epoxy, interface pads, phase change, double faced tapes) placed between two surfaces where a thermal transfer is desired.
- **Conduction:** Heat transfer within a solid to a cooler area.
- **Natural Convection:** Heat transfer that takes place in the absence of an air mover. Density changes create air movement. (Chimney effect)

Heat Sink Technical Terms (cont)

- **Forced Convection:** Heat transfer that takes place with an air mover (Fan , Blower).
- **CFM:** Cubic Feet per Minute. Used in reference to the volume of air passing through the cooling system.
- **LFM:** Linear Feet per Minute. Used in reference to the speed of air somewhere in the system.

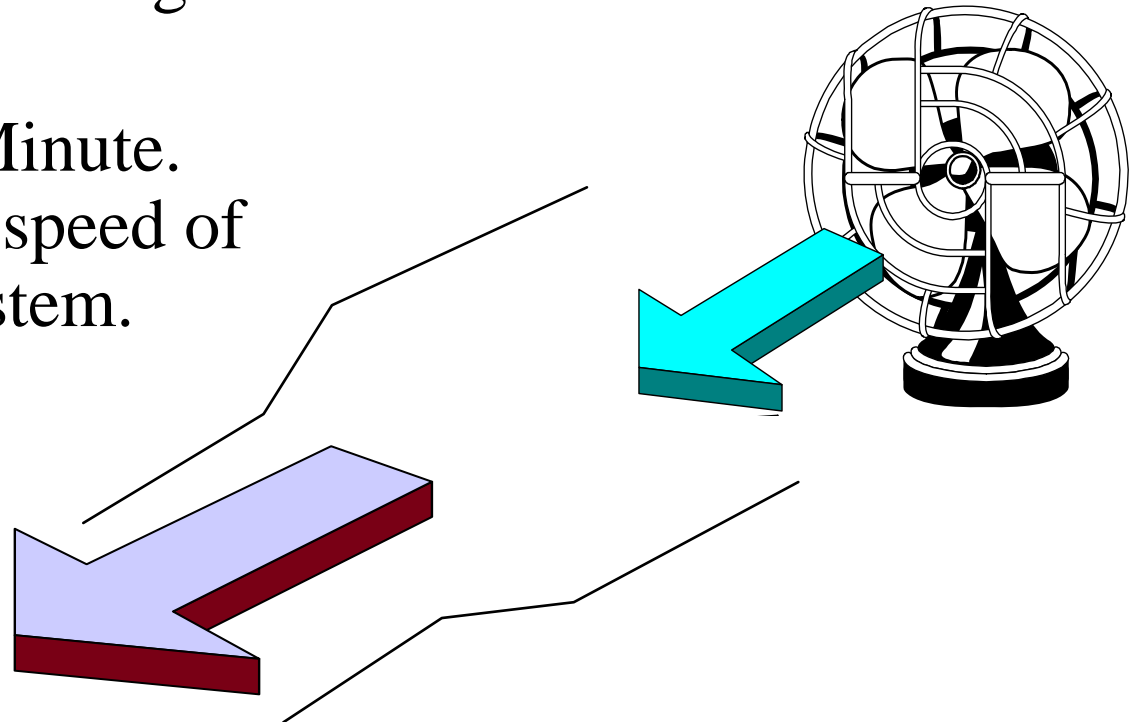

Stamped Heat Sinks

- **Stamped** : Heat sinks formed from flat stock by tooling and a punch press. These are ideal for low power printed circuit board level cooling solutions. Single LED's TO-220's TO-247 TO-3P's
- Heat sink to device mounting can be heat sink features, stainless steel clips, standard hardware of screw washer and nut.
- Heat sink to printed circuit board mounting, twist tabs. solder able tabs, pins, and standard mounting hardware.
- Standard finish for this type of product is Black Anodize or Matte Tin for solderable style products

Stamped

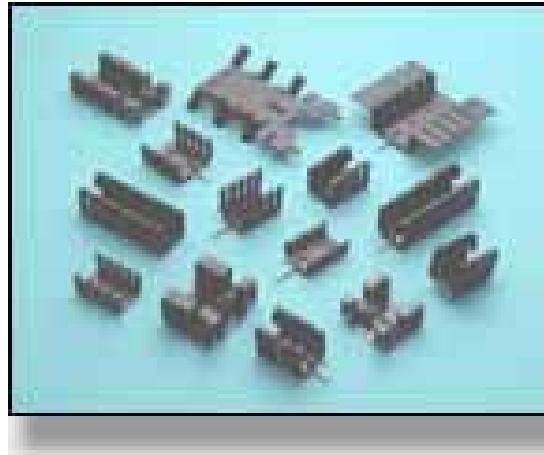

Extruded Heat Sinks

- **Extruded:** Made from aluminum which has been pushed through a die at a high temperature to give a constant cross section profile.
- 6063 alloy has highest thermal conductivity of the 6000 series aluminum.
- Extrusions can be designed for natural or forced air applications. Medium to low fin density natural convection, high fin density forced convection designs / applications.
- Extrusion details. Screw bosses, PCB slots, serrated fins
- Finishes available: Wash, Clear Chromate, Anodize, Paint

Extruded Heat Sinks

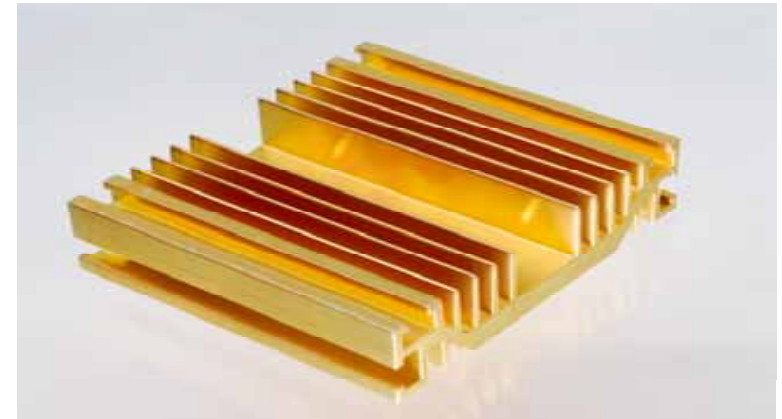
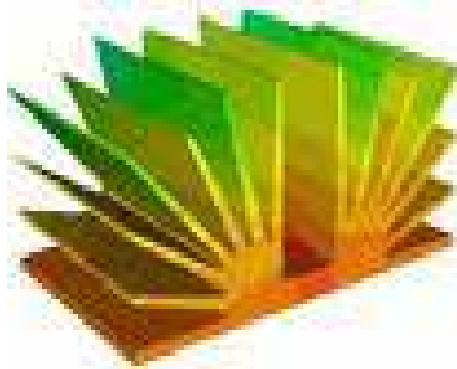

EXTRUSION CATALOG DATA

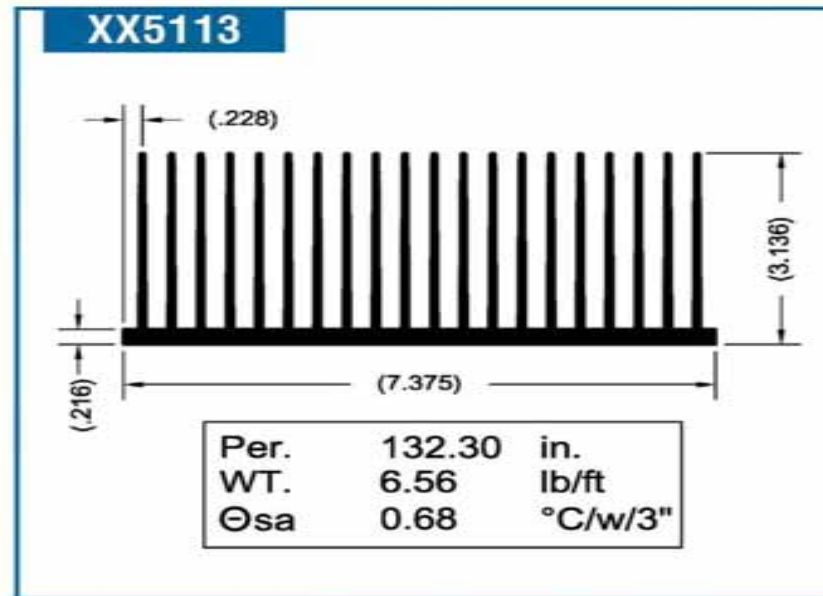

Per = surface area for 25.4mm length

WT = pounds per foot

⊕ SA = Thermal resistance for 76mm pc black anodized natural convection, uniform heat load.

Bonded Fin Heat Sinks

- **Bonded Fin** : Fabricated from an extruded base having slots into which straight fins are epoxy bonded, brazed, or soldered.
- Materials to construct are aluminum and copper. These materials are used depending upon required thermal performance. Copper has 1.8X thermal conductivity of aluminum but has a 3.3X weight factor. Or use a mixture of aluminum and copper materials.
- These products can range from 50.8mm to over 1000mm widths. The fin heights can range from 25.4mm to 200mm. Spacing of fin center to center for high velocity air flow starting at 3mm to 10mm for natural convection cooling applications.
- Finishes for bonded fin; Wash and chromate. (not anodized)

Bonded Fin

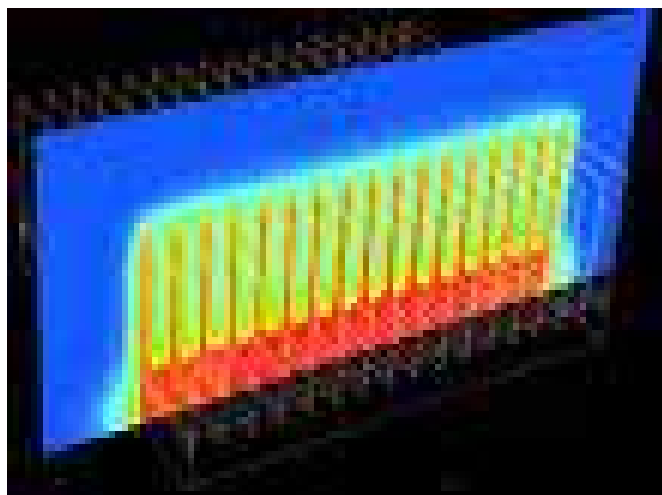
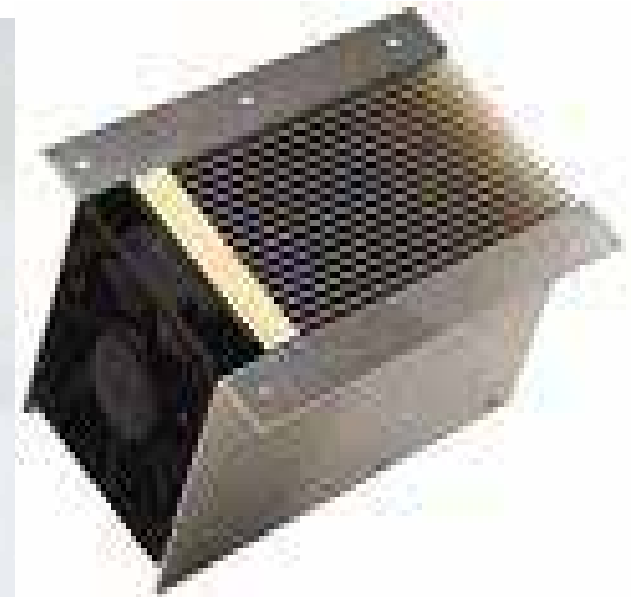
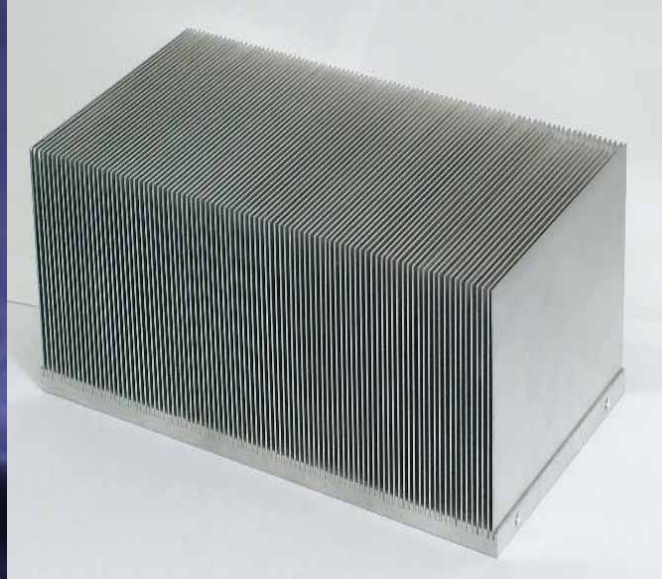
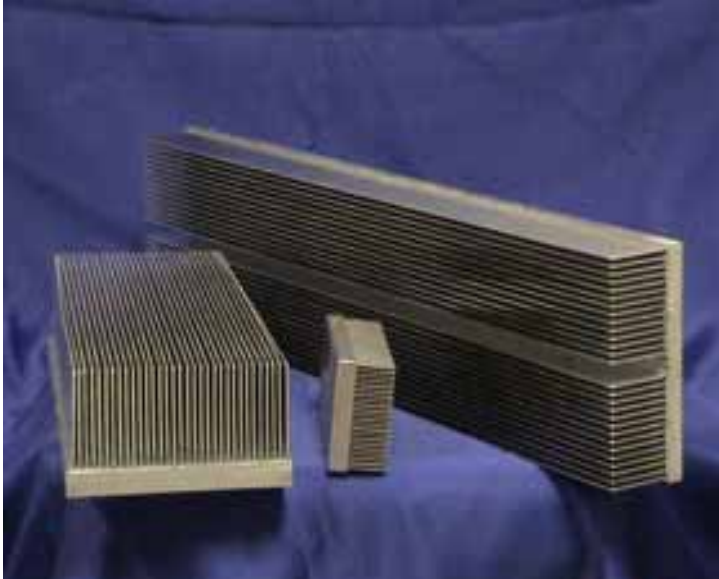

Folded Fin Heat Sinks

- **Folded Fin** : Having a fin structure made from sheet stock folded into a square wave shape. Accordion style formed material.
- Material thickness ranges from .13mm to 1mm. Aluminum and Copper alloys available.
- Fin Heights for flat or round crested fins can range from .5mm to 101.6mm
- Folded fin sinks need a shroud / cover to protect fin structures from handling damages
- Ideal for forced convection designs and applications
- Finishes: Wash, Chromate.

Folded Fin

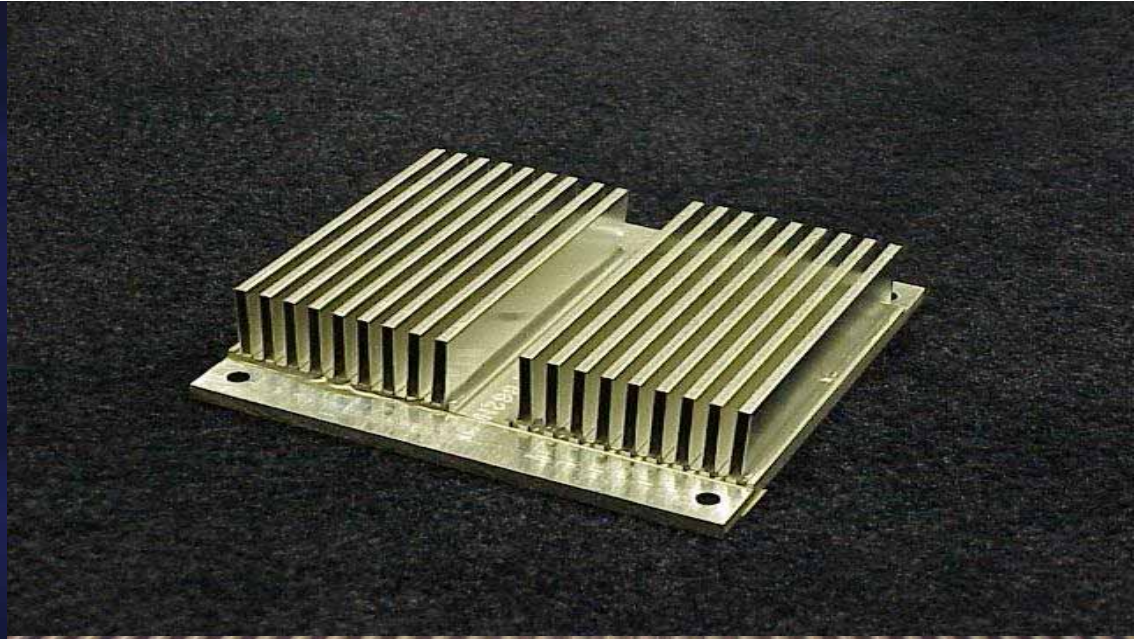

Liquid Cooled Heat Sinks

- **Cold Plate:** Aluminum plate with copper tubing fastened to it which uses liquids as the working fluid. Water, Water Glycol
- Cold plate tubing diameter's can range from 6.35mm to 25.4mm, base materials for tubing copper or stainless steel depending on end product environment.
- Custom designs as well as standards of 2 pass to 6 pass cooling available.
- Finishes: Wash, Chromate

Cold Plate

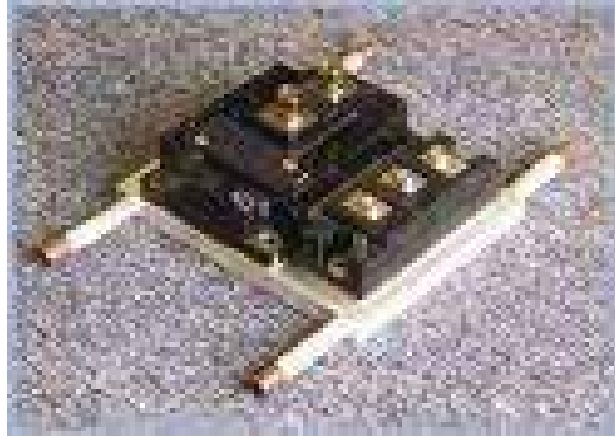

Devices That Are Cooled



Hockey Puck



Stud Diode



Bridge Rectifier



LE
D



Surface Mount



TO-247

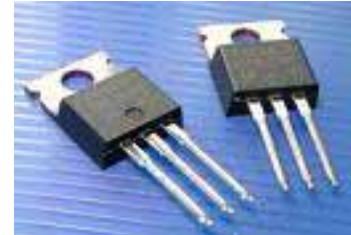

TO-220

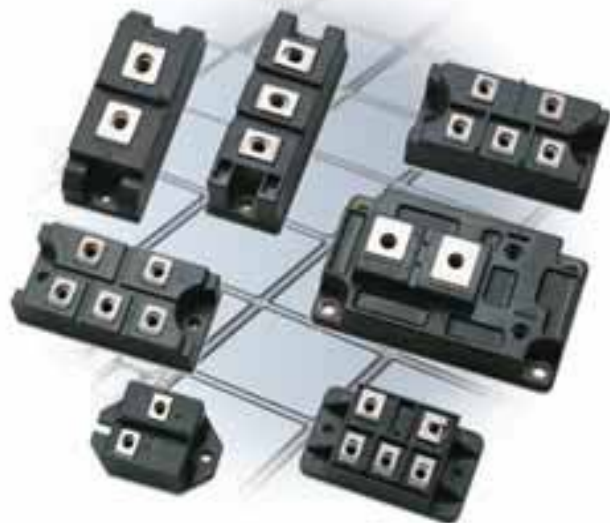

Power Block / IGBT



DC DC

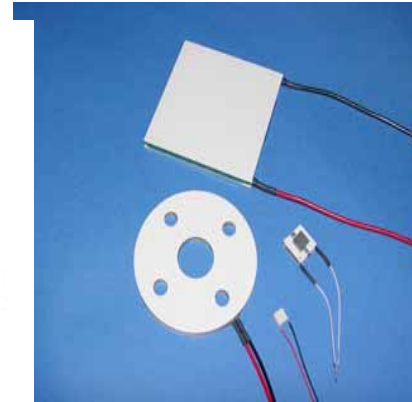

Thermal Electric
Peltier Device



TO-

Heat Sink in Natural Convection

- Temperature rise above ambient at 3.5 Watts is 23°C
- If ambient is 35 °C, then:
 $T_{\text{sink}} = 35 + 23 = 58 \text{ °C}$
- Need to watch **ORIENTATION** of heat sink
- More fins is not always better!

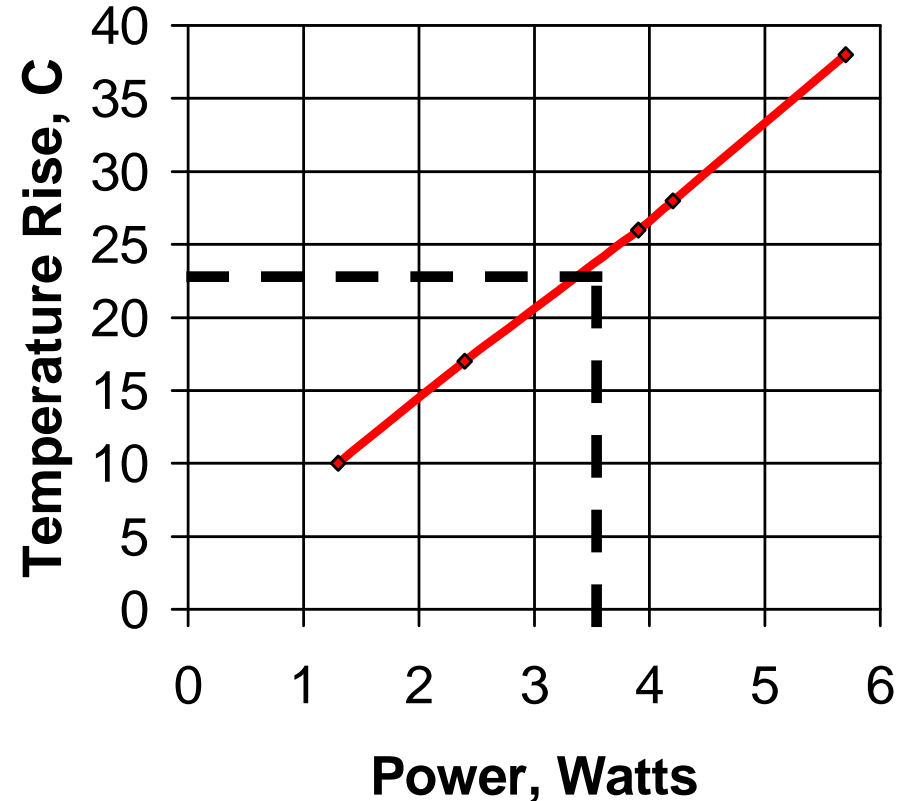

Heat Sink in Forced Convection

∞ Thermal Resistance at 150 LFM is 2.4°C/W.

∞ Temperature Rise of heat sink **above ambient** is:
(2.4°C/W)(Power)

∞ If Power = 5 Watts, and ambient temp is 35°C, heat sink temp is:
(2.4°C/W)(5W) = 12 °C
 $T_{\text{sink}} = 35 + 12 = 47 \text{ °C}$

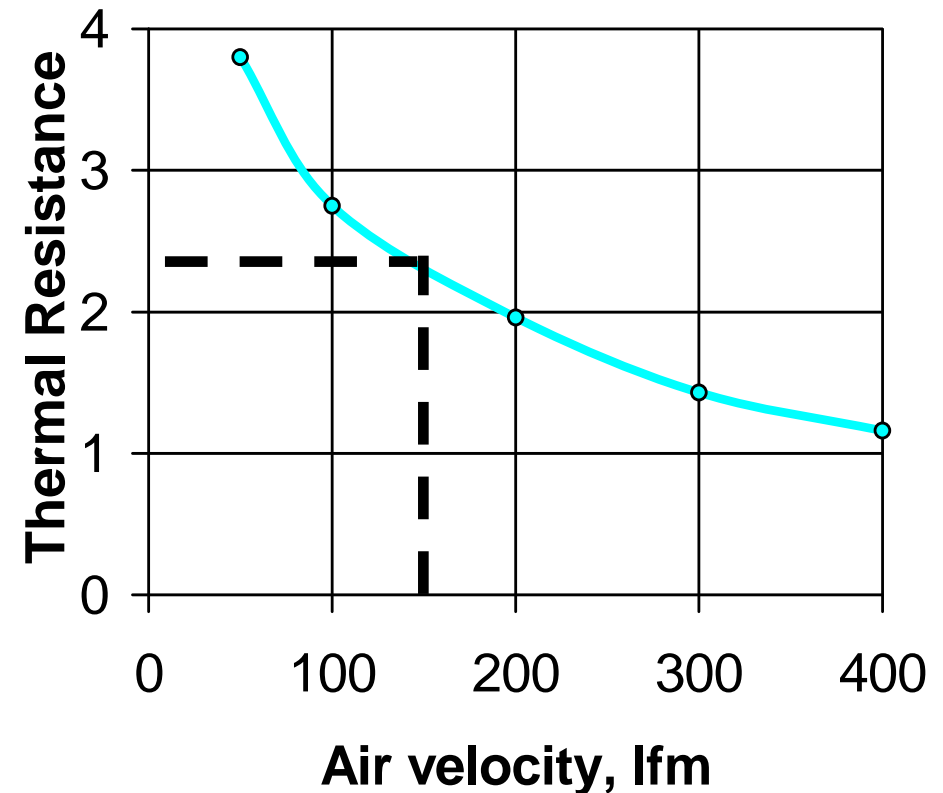

How Much Air is There?

- We use a fan curve to determine how much air.
- All flow systems have an impedance curve
- Amount of air depends on intersection of two curves
- Sometimes more fins is worse.

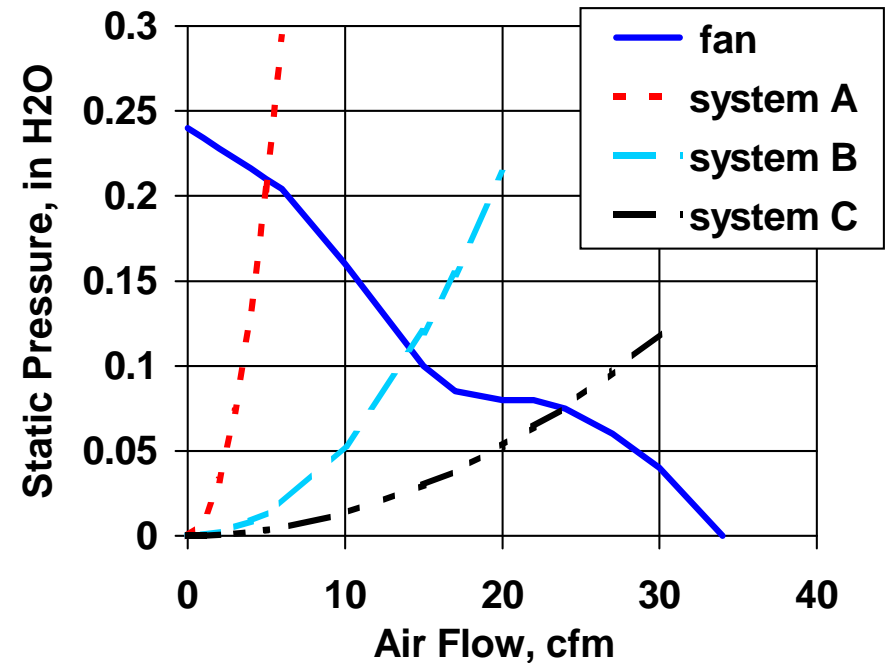

Remember, more air is always better!

Performance Graphs in Catalog

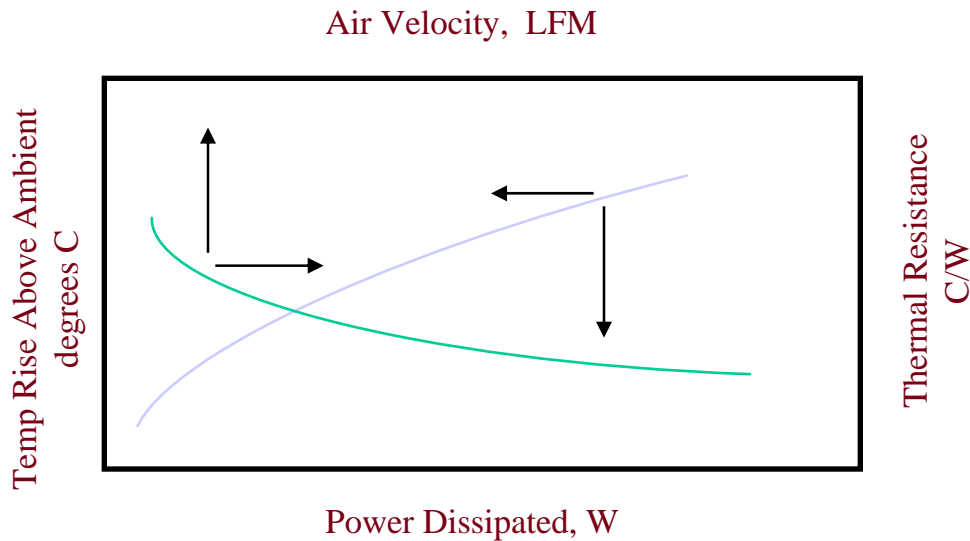
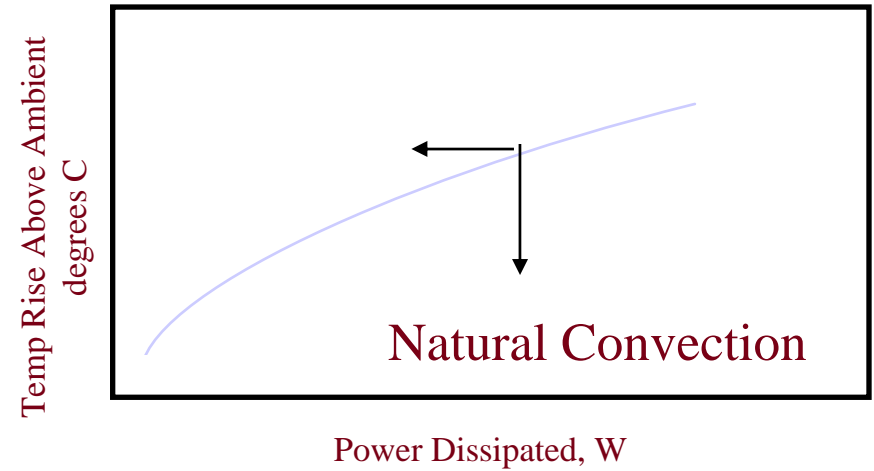
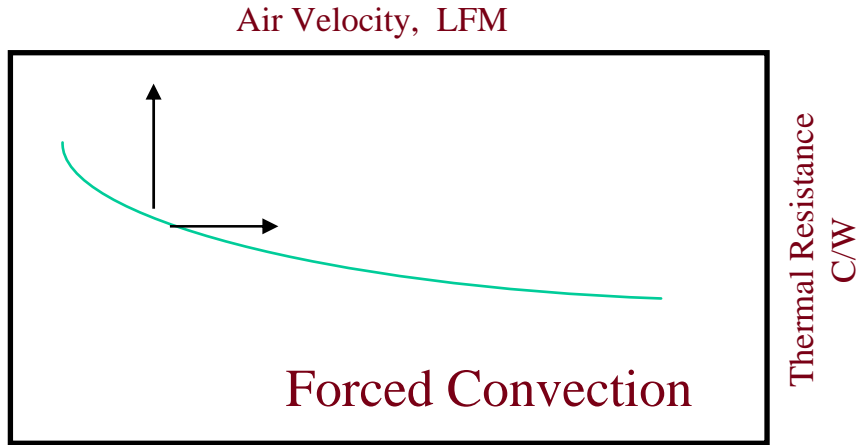

Extruded Heat Sinks - Materials

- Available Aluminum alloys for extrusion: 6005, 6061, 6063, 6082, 6105, 6463
- Tempers (for 6063):
 - T4: Solution heat treated and naturally aged (not machinable)
 - T5: Cooled from an elevated temperature and artificially aged
 - T6: Solution heat treated and artificially aged
 - T52: Similar to T6, but also roll-formed
- 6063 is most desirable for heat sinks for extrudability and thermal properties.

Extruded Heat Sinks - Capabilities

- Extrusion Presses: 3000 ton and 1800 ton, with circle size up to 28mm (330mm maximum diameter)
- Fin aspect ratios up to 18:1+ are possible
 - Aspect ratio = Fin height/air gap between fins (See Next Slide)
- Hollow shapes are extruded regularly; multiple hollows are also possible.
- Submit shapes to Wakefield for extrudability/feasibility analysis.

Extruded Heat Sinks - Capabilities

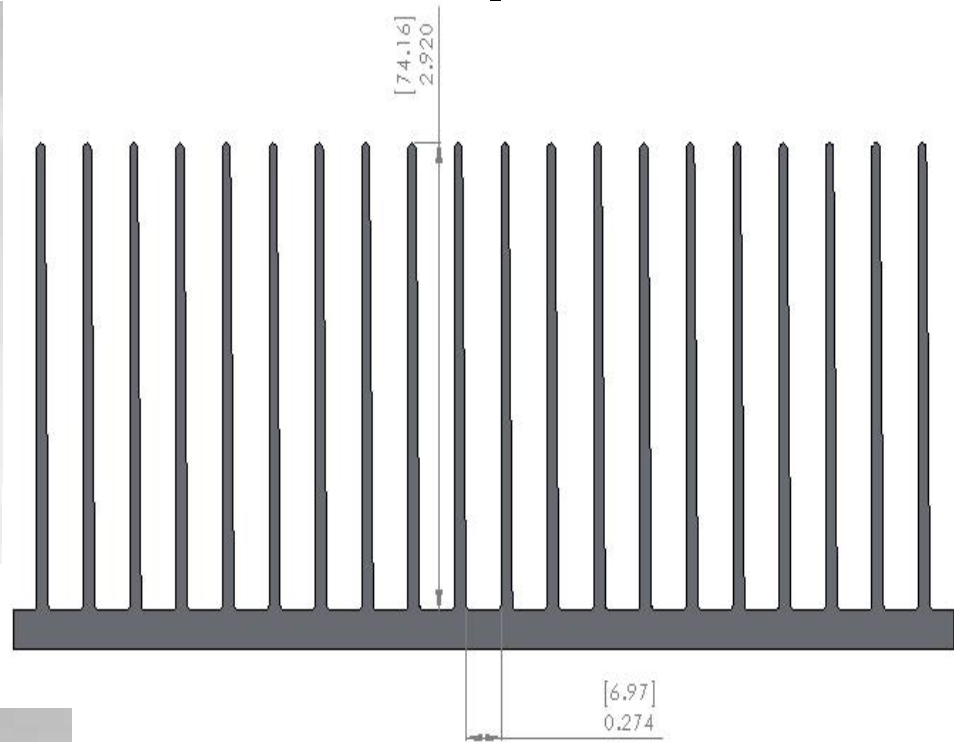
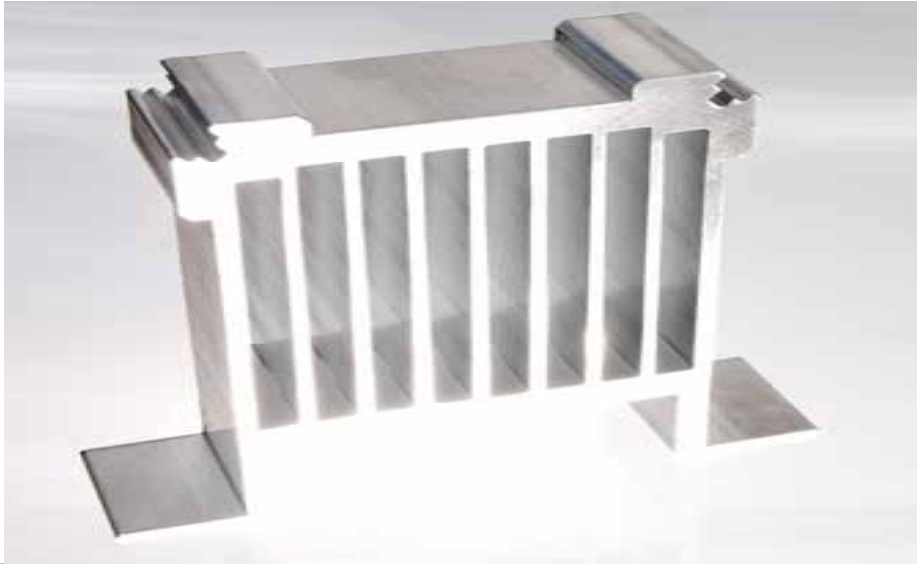

EXTRUSION RATIO
 $74.16/6.97 = 10.6 \text{ TO } 1$



Extruded Heat Sinks - Capabilities

- Tolerances based on standard Aluminum Association tolerances - fully defined in Standard Al Shapes catalog.
- Tolerances for features of size depend on a number of factors, including:
 - Nominal value of dimension
 - Die circle size (overall size of shape)
 - Dimension mostly metal vs. mostly air
 - Solid vs. hollow vs. semi-hollow
- In some cases, Wakefield can provide half of standard tolerance or less - check with Wakefield first!

Extruded Heat Sinks - Capabilities

- Flatness as extruded: .1mm to .2mm per 25.4mm length on a heat sink base. This depends on width of extrusion and base thickness. - flatter parts need secondary operation
- Surface finish as extruded: 125 / 63 - contact Wakefield for tighter requirements secondary operation.



Fabricated Heat Sinks - Capabilities

- Secondary operations
 - CNC machining: milled cutouts, drill, tapped holes
c'bores chamfers
 - Punch press: holes, cutouts in flat surfaces
 - Fly cut: produces flatness of .025mm per 25.4mm of
length on heat sink base
 - Black Anodize - for visual, corrosion protection, or to
enhance thermal performance in natural convection
 - Chromate conversion
 - Painting, silk screening

Fabricated Heat Sinks - Capabilities

- Standard manufacturing tolerances
 - Cut length: $\pm.51$ mm general, $\pm.25$ mm possible
 - Edge-hole position: $\pm.51$ mm general, $\pm.25$ mm possible
 - Hole-hole position (CNC, punch): $\pm.13$ mm
 - Hole diameter (CNC, punch): $\pm.051$ mm
 - Hole-hole position (extruded screw boss): Aluminum Association tolerances
 - Hole diameter (extruded screw boss): Aluminum Association tolerances ($\pm.15$ mm min)
 - Note: extruded screw bosses are not fully enclosed!

Fabricated Heat Sinks - Capabilities

- Assembly operations
 - Inserts, Fasteners, Hardware, Heli-Coils or Custom parts
 - Thermal interface attachment
 - Double Faced Thermal Tapes
 - Hot stamp for phase-change material
 - Delta pads, Thermal Interface Pads, Special Die Cut
 - Assembly, fastening of multiple parts Welded & Bonded Assemblies.

Fabricated Heat Sink

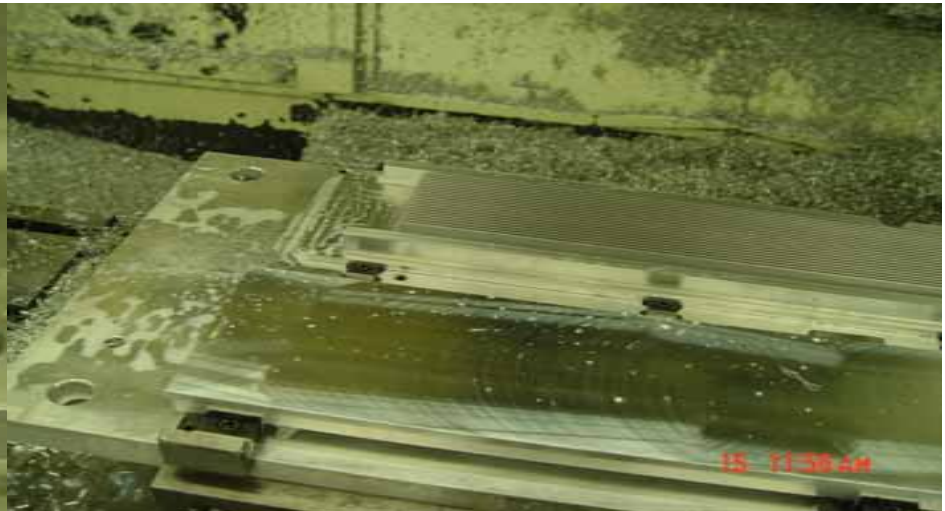
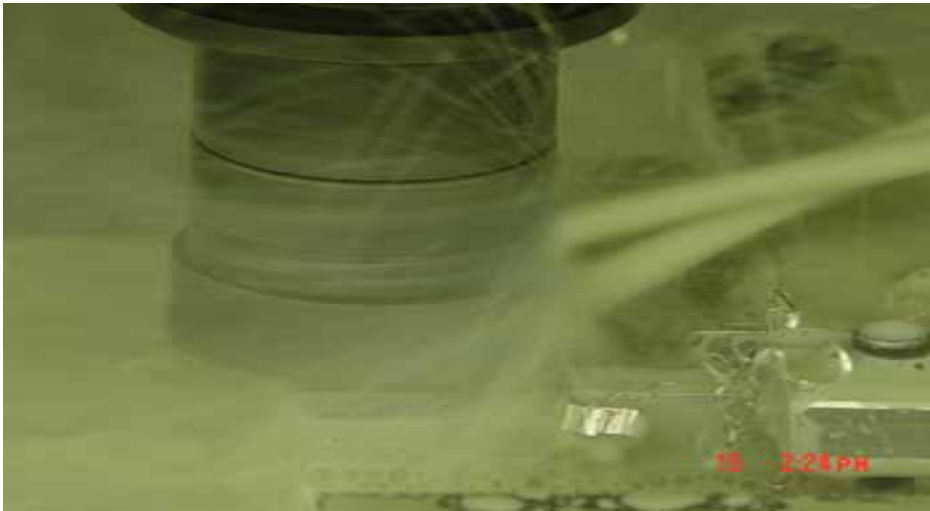

LED Concept Heat Sink

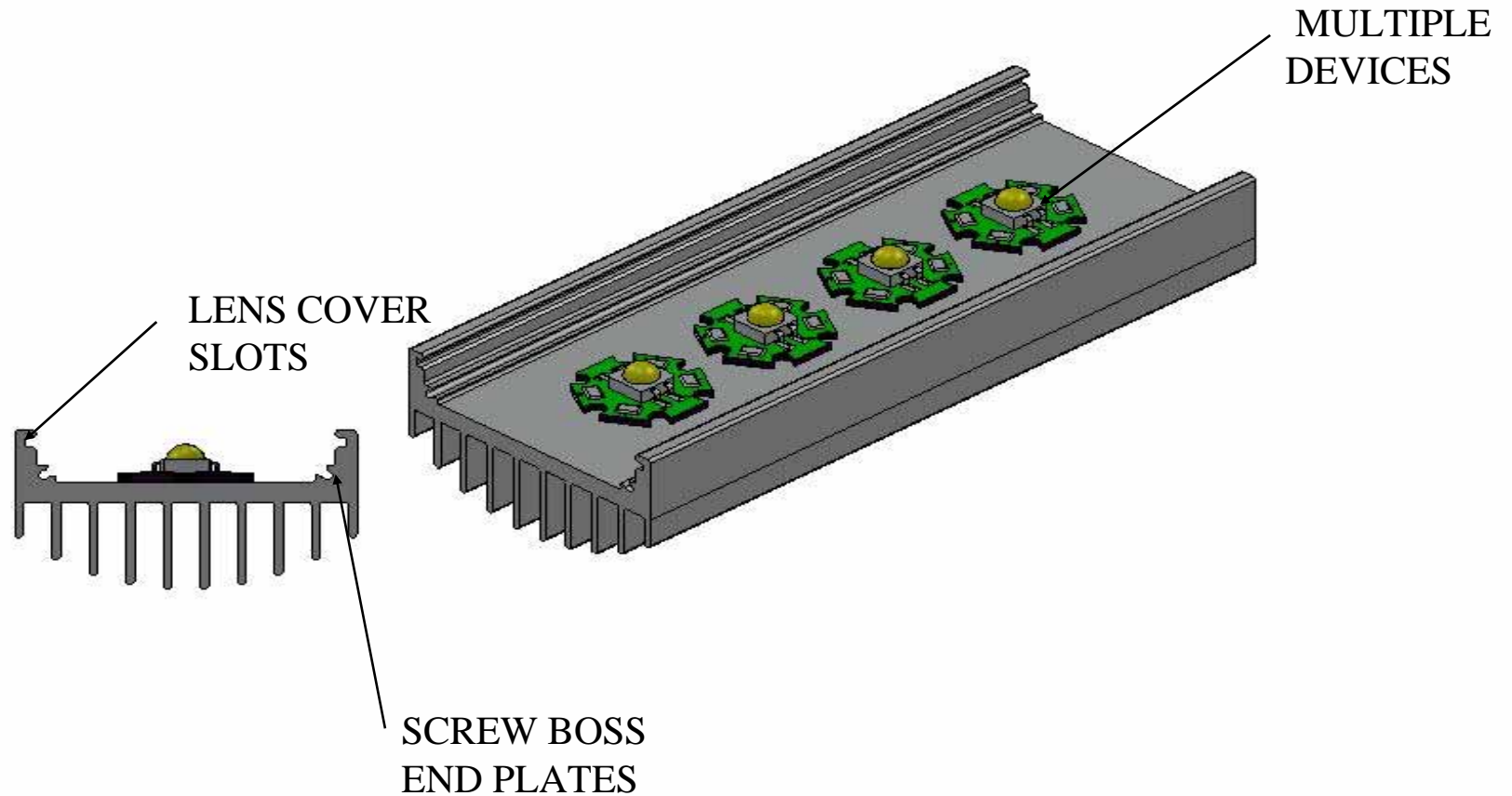

LED Concept Heat Sink

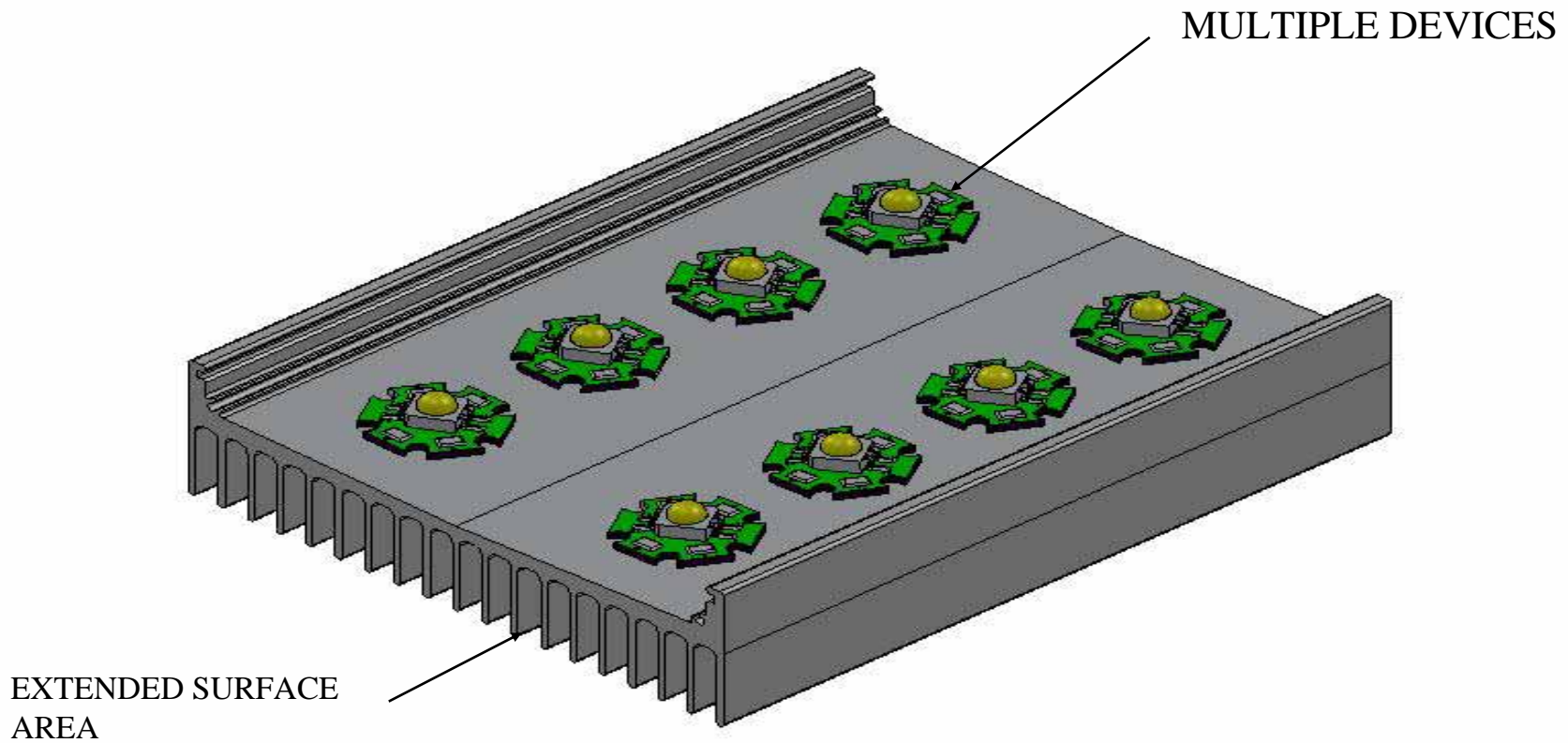

LED Concept Heat Sink Features

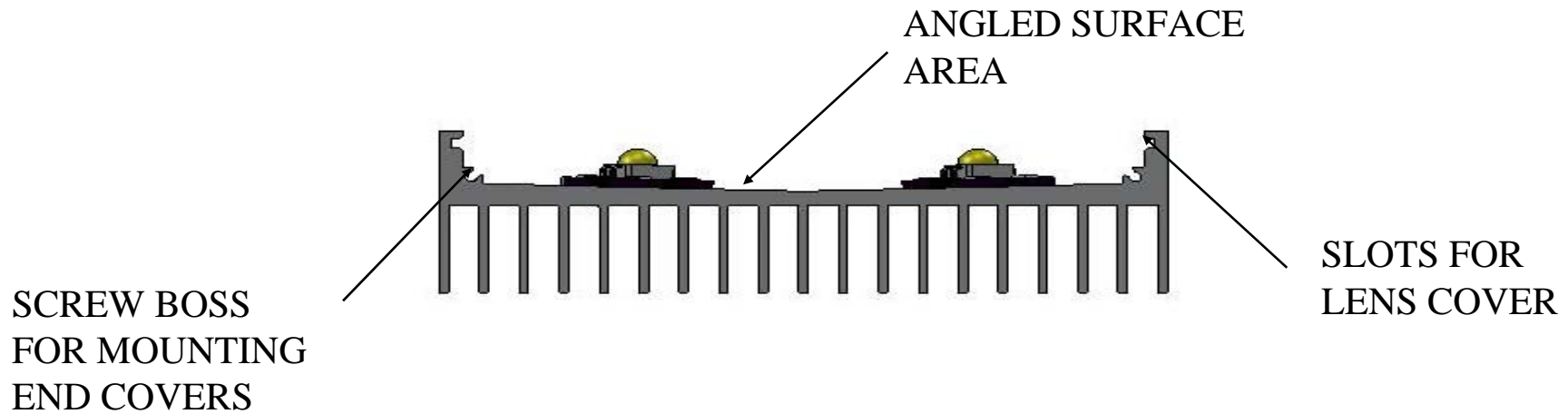

LED Concept Heat Sink

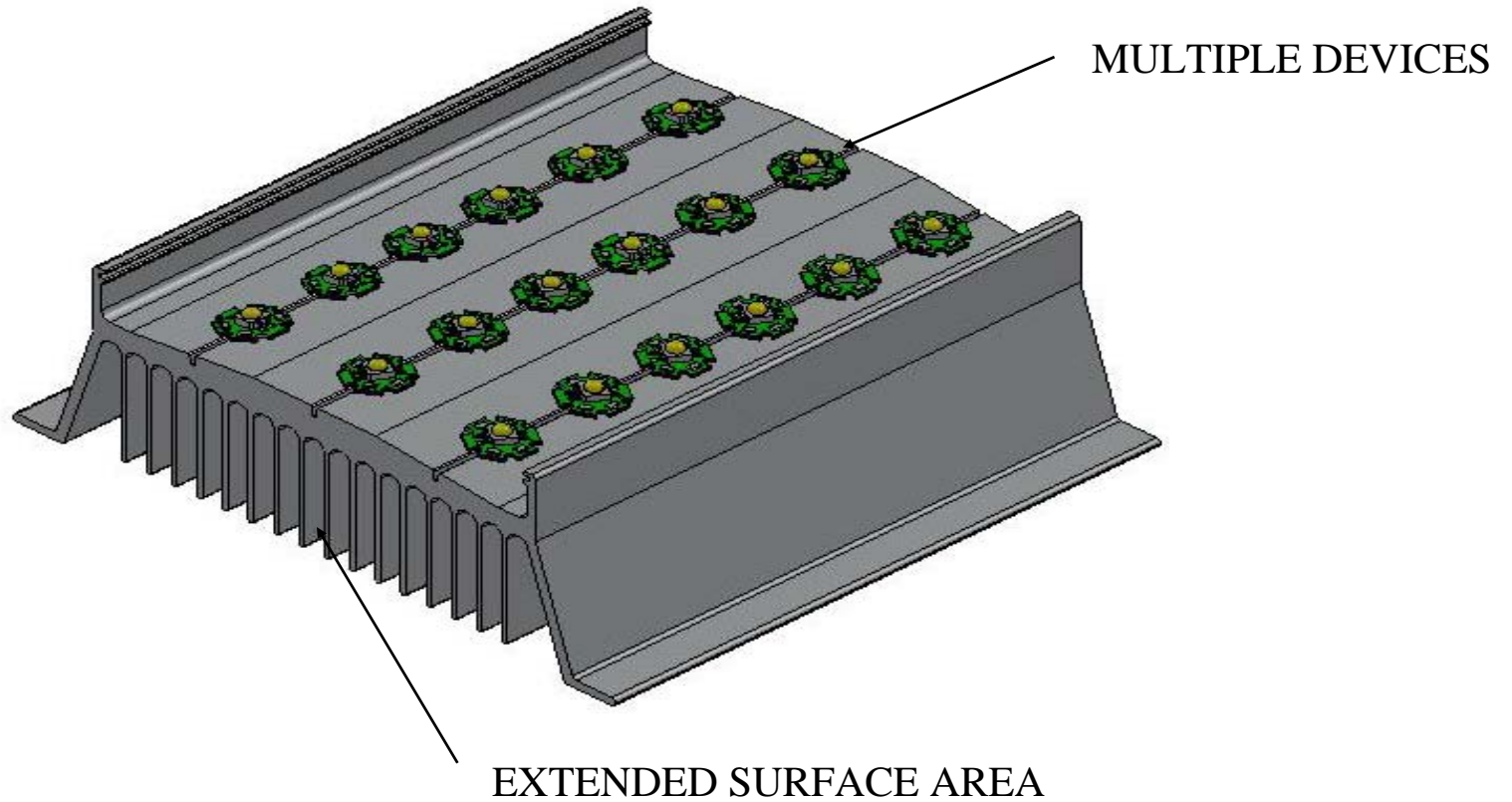

LED Concept Heat Sink Features

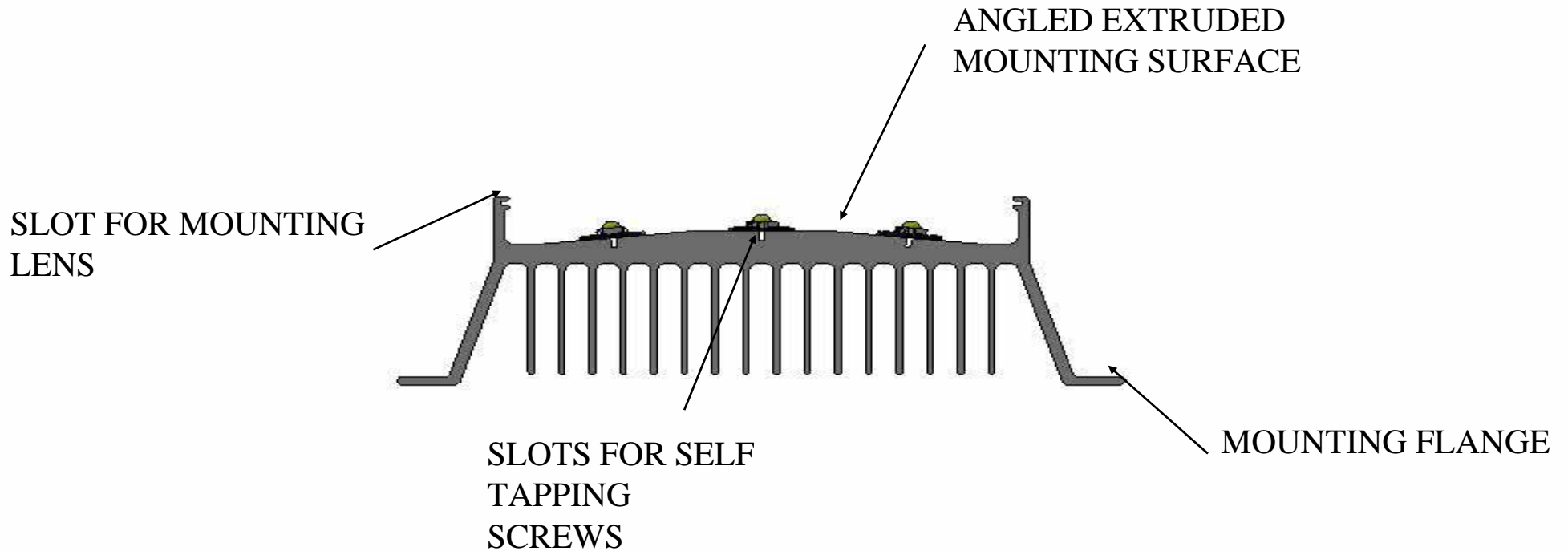

LED Concept Heat Sink

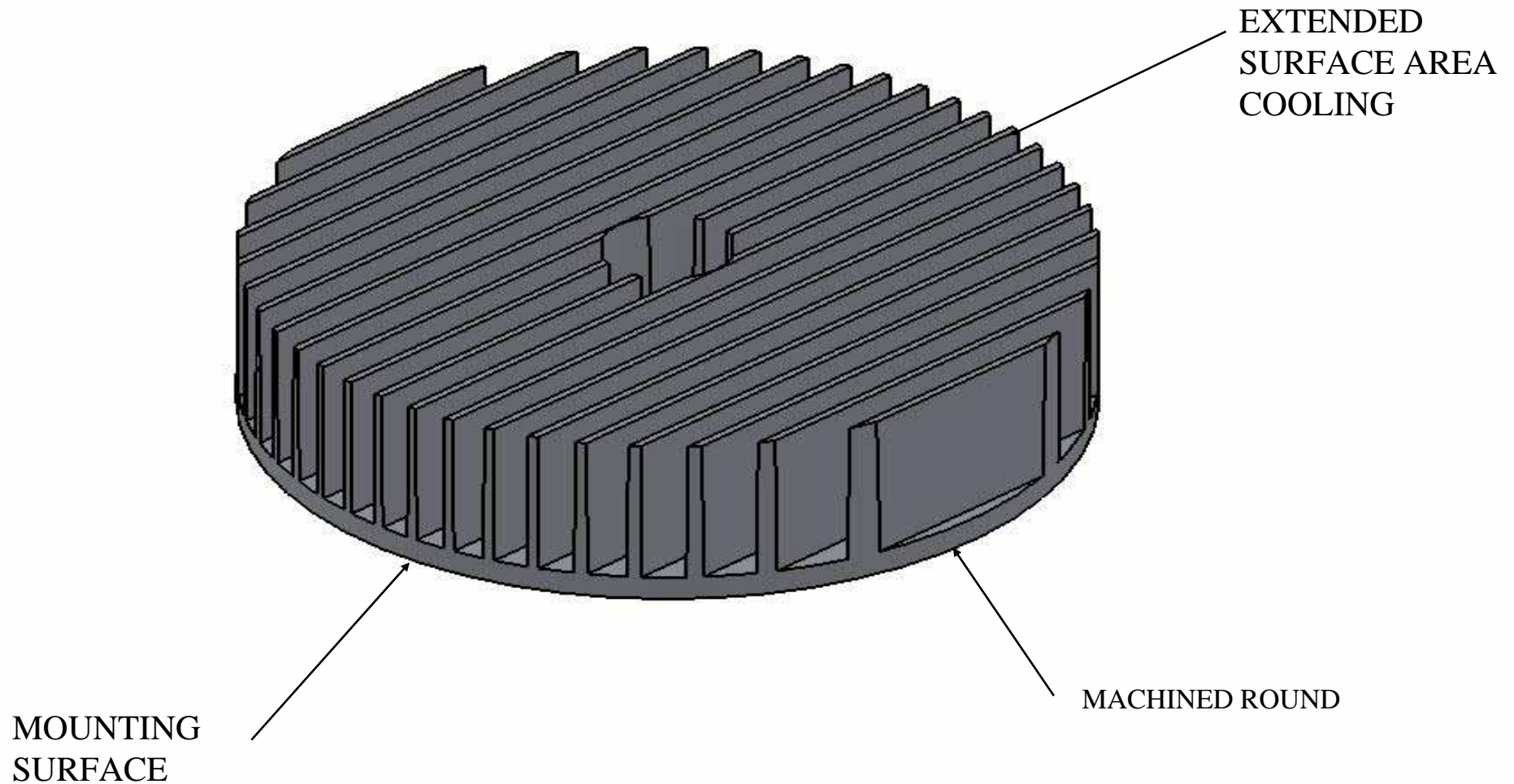

LED STANDARD PART

JTI – HEAT SINKS FOR POWER LEDs

882 SERIES – RADIAL FIN HEAT SINK FOR “STAR” LED PACKAGES

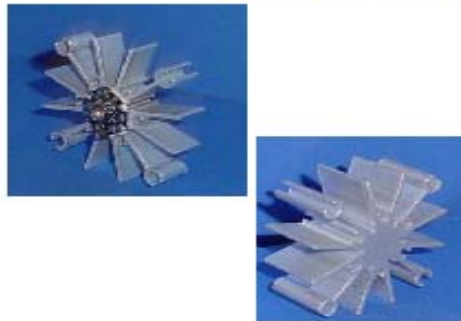

Wakefield's new 882 series heat sinks can be used with LEDs in the star package from Lumileds, Osram, and others. The radial design and fin area is ideally suited for natural convection applications such as ceiling lighting. A fan can also be used for increased performance in a forced convection application. Three sets of mounting holes allow maximum flexibility.

- The six .090 holes accommodate the LED module with # 4-40 screws.
- The six .153 holes can accommodate a multi-LED circuit board, mount to a panel with # 10-32 screws, or act as a conduit for wires
- The four .201 holes can be used to mount the heat sink to a panel with # 1/4-20 screws

Standard P/N	Height "A" in (mm)	Natural Convection Temp rise over ambient	Forced Convection Thermal resistance @200LFM	Weight lbs (grams)
882-50AB	0.50 (12.7)	60 °C @ 9 W	4.33 °C/W	0.073 (34)
882-100AB	1.00 (25.4)	48 °C @ 9 W	2.88 °C/W	0.146 (67)
882-200AB	2.00 (50.8)	36 °C @ 9 W	1.89 °C/W	0.293 (133)
882-300AB	3.00 (76.2)	28 °C @ 9 W	1.55 °C/W	0.439 (199)

MECHANICAL DIMENSIONS

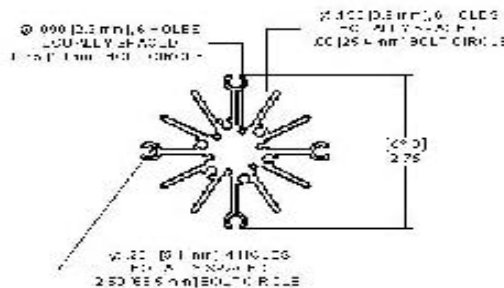

NATURAL AND FORCED CONVECTION CHARACTERISTICS

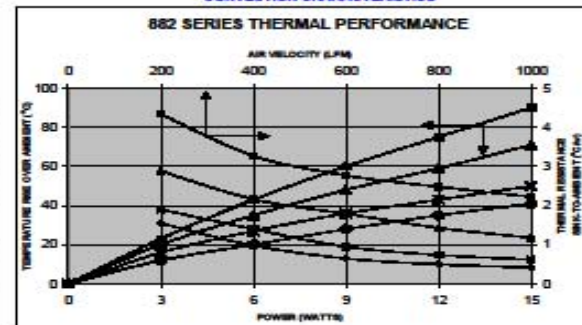

Wakefield Thermal Solutions believes that information provided is accurate as of publication date. Product testing in customer applications is recommended. The physical properties reported are representative of performance values obtained by standard predictive and testing methods. Wakefield Thermal Solutions is a manufacturer of heat dissipation products and reserves the right to make changes to its products without notice to improve the design or performance characteristics.

Other Heat Sinks

Majority of Wakefield's business is custom

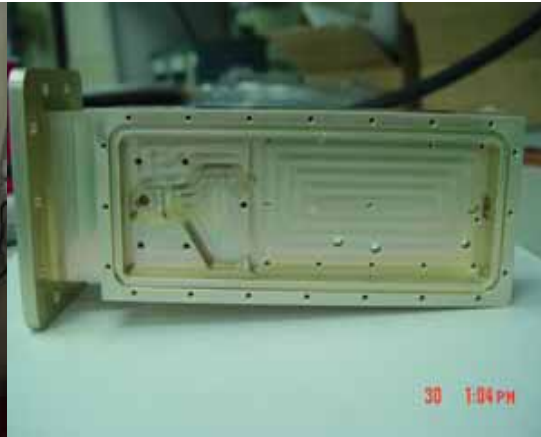

Other Heat Sinks

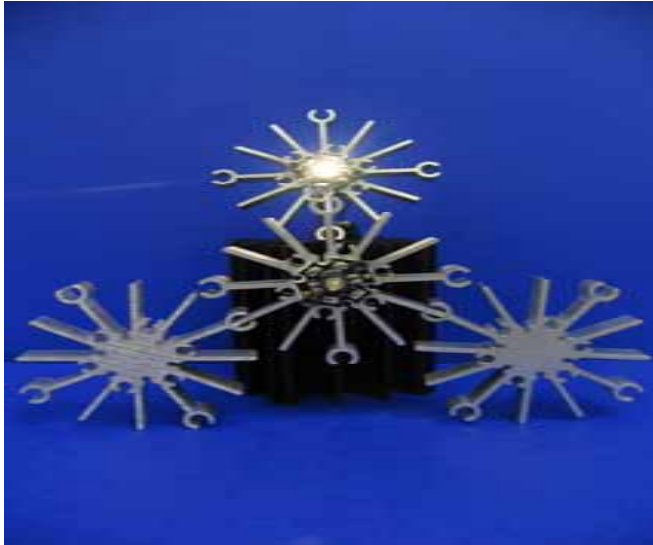

17 10:09 AM

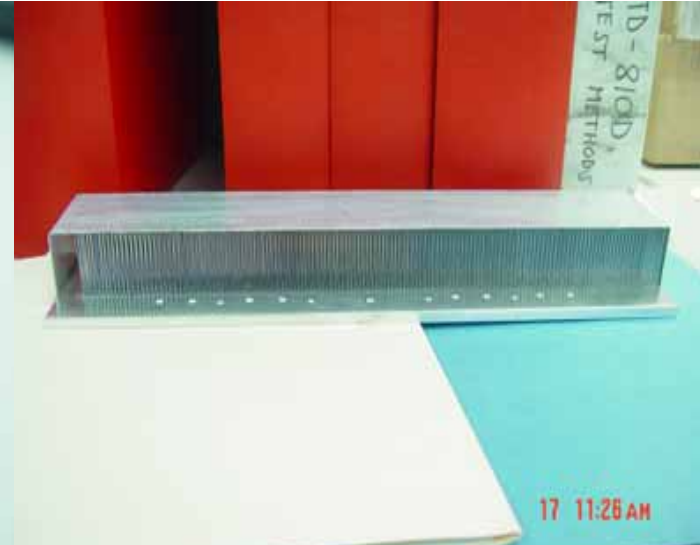

17 11:26 AM



12 4:21 PM



22 2:02 PM



1 9:15 AM

Other Heat Sinks

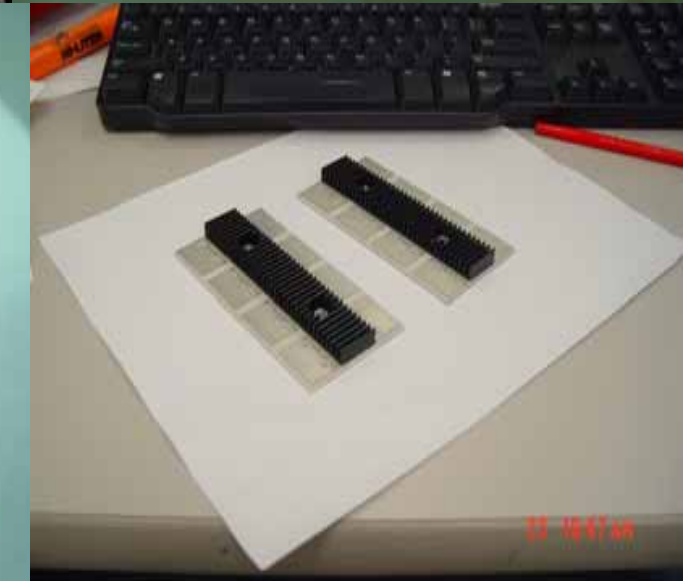
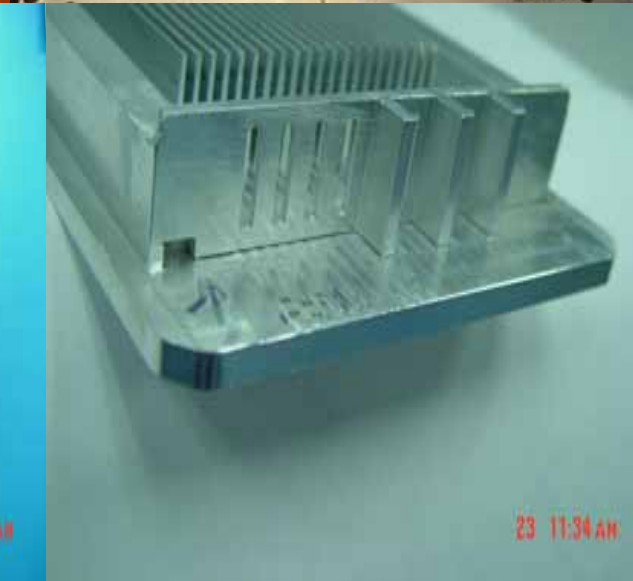

Other Heat Sinks



Other Products

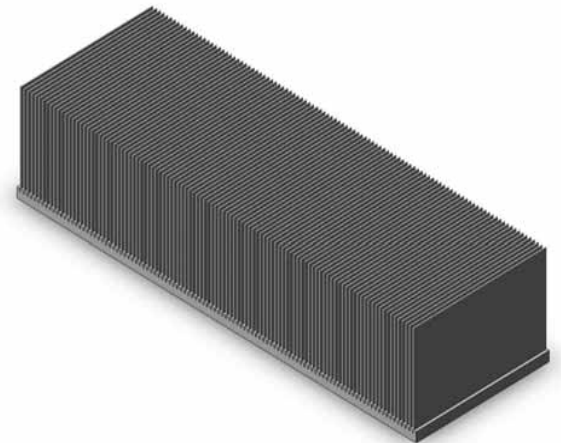

Wakefield Thermal Solutions Inc

QUESTIONS & ANSWERS

THANK YOU FOR ATTENDING

WWW.WAKEFIELD.COM